

The Melville

1703 sq.ft.

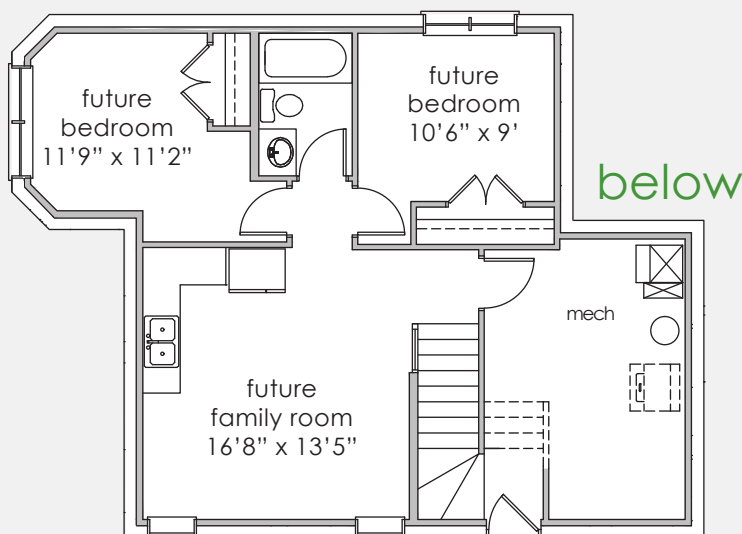
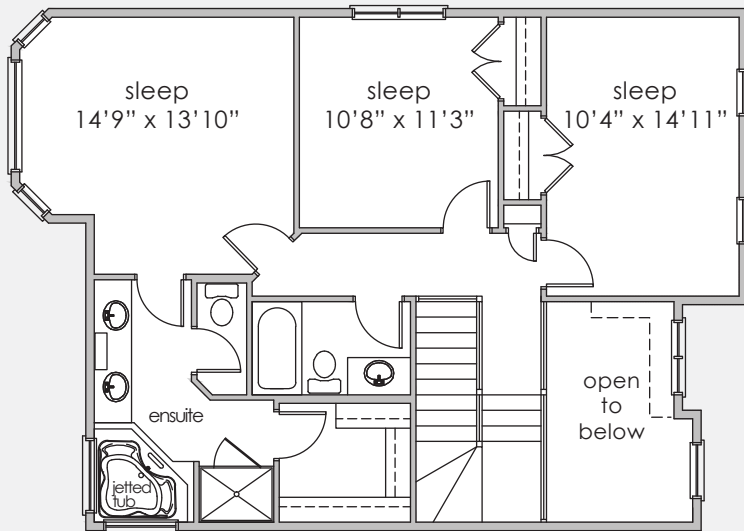
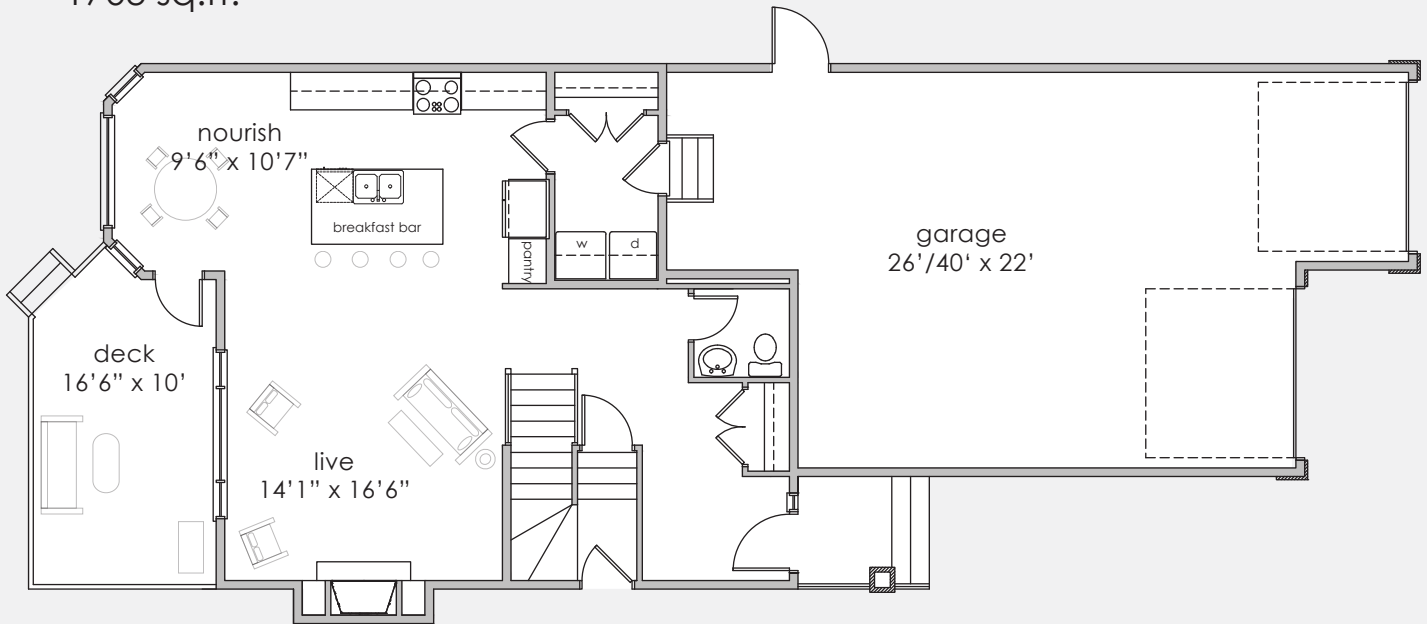

below

- 3 bedrooms with 2.5 baths
- Oversized three car garage
- 9' ceilings (main floor and basement)
- Separate basement entrance
- Stainless kitchen appliances
- Glass backsplash
- Oversized pantry cabinet
- Main floor laundry
- Fibre optic to the home (telus)
- Landscaping (front)

